

Serial FLASH Programming User's Guide



Release 09.2025

Serial FLASH Programming User's Guide

TRACE32 Online Help

TRACE32 Directory

TRACE32 Index

TRACE32 Documents	
FLASH Programming	
Serial FLASH Programming User's Guide	1
Introduction	4
How This Manual is Organized	4
Related Documents	4
Contacting Support	5
List of Abbreviations	7
Background Knowledge	8
What is a Serial Flash Device?	8
About SPI Interface Controllers in Serial Flash Memories	8
About Blocks and Pages	9
File Name Convention for Serial Flash Drivers	10
Standard Approach	11
Identifying and Running Scripts for Serial Flash Programming	11
If There Is No Script	13
Scripts for SPI Controllers	14
Establishing Communication between Debugger and Target CPU	16
Configuring the SPI Controller	17
Resetting Default Values	18
Informing TRACE32 about the Serial Flash Register Addresses (SPI)	18
Informing TRACE32 about the Serial Flash Programming Algorithm	19
Memory-Mapped serial Flash	19
Non-Memory-Mapped serial Flash	19
Identifying the Correct Driver Binary File for a Serial Flash Device	20
Finding the <serialflash_code> of Your Serial Flash Device	21
Example for SPI Controllers	23
FLASHFILE Declaration Examples	24
Declaration Example for STM32F103 (Cortex-M3)	24
Declaration Example for AT91SAM9XE (ARM9)	25
Checking the Identification from the Serial Flash Device	26
Erasing the Serial Flash Device	27
Programming the Serial Flash Device	28

Copying the Serial Flash Memory	29
Modifying the Serial Flash Memory	31
Other Useful Commands	32
Reading the Serial Flash	32
Saving the Serial Flash Device	33
Full Examples	34
Example 1	34
Example 2	36
FLASH Programming via Boundary Scan	37
Example 1 for the SPI Protocol	37
Example 2 for the I2C Protocol	39

Introduction

This manual describes the basic concept of serial Flash programming.

How This Manual is Organized

- **Background Information:** Provides information about important terms in serial Flash programming, such as SPI interface controller, block, and page.
- **Standard Approach:** Describes the fastest way to get started with SPI serial Flash programming. All you need to do is to identify and run the correct script.
Demo scripts for SPI serial Flash programming are available in the folder:
 - `~/demo/<architecture>/flash/*.cmm`
 - e.g. `at91sam9xe-spi.cmm`, `stm32f10x-spi.cmm`, `str910-spi.cmm`, ...
- **New Scripts for SPI Controllers:** Describes how you can create a script if there is no demo script for the SPI controller you are using.

Related Documents

A complete description of non memory mapped serial Flash programming commands can be found in chapter “FLASHFILE” in “General Commands Reference Guide F” (`general_ref_f.pdf`).

A complete description of memory mapped serial Flash programming commands can be found in chapter “FLASH” in “General Commands Reference Guide F” (`general_ref_f.pdf`).

The Lauterbach home page provides an up-to-date list of

- Supported Flash devices under:
www.lauterbach.com/supported-platforms/toolchain/flash-devices
- Supported serial Flash controllers under:
www.lauterbach.com/supported-platforms/toolchain/flash-controllers

Contacting Support

Use the Lauterbach Support Center: <https://support.lauterbach.com>

- To contact your local TRACE32 support team directly.
- To register and submit a support ticket to the TRACE32 global center.
- To log in and manage your support tickets.
- To benefit from the TRACE32 knowledgebase (FAQs, technical articles, tutorial videos) and our tips & tricks around debugging.

Be sure to include detailed system information about your TRACE32 configuration.

1. To generate a system information report, choose **TRACE32 > Help > Support > Systeminfo**.

The screenshot shows the 'Generate TRACE32 Support Information' dialog box. The form is filled with the following data:

Company:	Lauterbach	Department:	
Prefix:			
Firstname:	Andrea		
Surname:	Martin		
Street:	Altlaufstr. 40	P.O. Box:	
City:	Hoehenkirchen-Siegertsbr.	ZIP Code:	85635
Country:	Germany		
Telephone:	(+49) 8102-9876-555		
eMail:	andrea.martin@lauterbach.com		
Product:	PowerTrace PX		
Target CPU:	ARM940T		
Hostsystem:	Windows 10		
Compiler:	Arm		
RealtimeOS:	Nono		

At the bottom of the dialog box, there are three buttons: 'Generate Support Information:', 'Save to Clipboard', and 'Save to File'. The 'Generate Support Information:' button is highlighted.

NOTE:

Please help to speed up processing of your support request. By filling out the system information form completely and with correct data, you minimize the number of additional questions and clarification request e-mails we need to resolve your problem.

2. Preferred: click **Save to File**, and send the system information as an attachment to your e-mail.
3. Click **Save to Clipboard**, and then paste the system information into your e-mail.

NOTE:

In case of missing script files (*.cmm), please proceed as requested in **“If There is No Script”**.

List of Abbreviations

The abbreviations vary from chip manufacturer to chip manufacturer.

MOSI or SI	Master output, slave input
MISO or SO	Master input, slave output
SCLK or SCK	Serial clock
SS	Slave select
SDI	Serial data input
SDO	Serial data output
CS or CE	CS = Chip selection CE = Chip enable
SPI	Serial peripheral interface
eMMC	Embedded multimedia card
MMC	Multimedia card
GPIO	General purpose input/output
SSI	Synchronous serial interface

Background Knowledge

This chapter of the manual is aimed at users who are new to serial Flash programming; it does not address experts with many years of expertise in this area. This chapter gives you a brief overview of important terms in serial Flash programming, such as serial flash device, sector, page, and SPI interface controller.

What is a Serial Flash Device?

A serial Flash device is a non-volatile memory that can be electrically erased and reprogrammed. It is used for storing executable code in devices such as DVD players, DSL modems, routers, hard-disk drives, and printers. After power-up, the executable code is downloaded from the serial Flash to RAM, and then executed by the processor. The code in the serial Flash is not changed by the download process and is write-protected.

Reasons for the widespread use of serial Flash devices include:

- Cost effective and space-saving solution thanks to a reduced number of pins
- Low power consumption
- Life cycle of about 20 years

About SPI Interface Controllers in Serial Flash Memories

Serial Flash memories consist of an interface controller (for example, a SPI interface controller) and a Flash memory. Access to the Flash memory is performed by the interface controller on the SPI slave side.

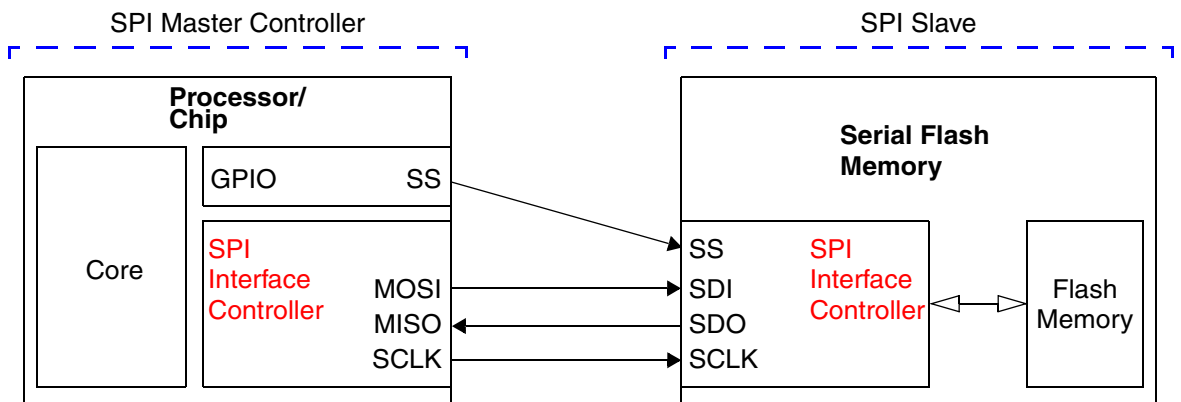

Figure: Processor/Chip and Serial Flash Memory with a SPI Interface

Serial Flash memories are controlled by many kinds of serial interface protocols (SPI, SSP, SSI, SMI, etc.). The protocol of the SPI interface (serial peripheral interface) specifies four signals:

- Slave select (SS)
- Master output, slave input (MOSI)
- Master input, slave output (MISO)
- Serial clock (SCLK)

Most chip manufacturers have proprietary SPI interface controllers (short: SPI controllers) and thus require special *driver binary files* for programming serial Flash memories. These driver binary files are *programs executed by a core in the target* and interact with the master SPI controller for controlling the SPI slave controller in order to program the serial Flash memory.

Once the required driver binary file was loaded to the target, the TRACE32's command group **FLASHFILE** can be used to program and erase the serial Flash memory.

Lauterbach provides driver binary files for a large number of SPI controllers. See further down for instructions how to identify the correct driver for your application.

About Blocks and Pages

The Flash memory of a serial Flash device consists of sectors, and each sector is subdivided into pages; see example diagram below.

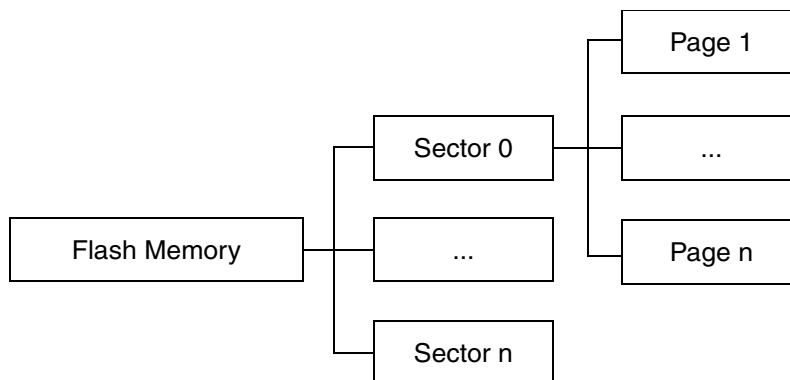

Sector A sector is the minimum size unit for erasing. A sector can have a size of 32, 64, or 256 KBytes.
The sector sizes are part of the file names of the algorithms required for serial Flash programming: `spi32*.bin`, `spi64*.bin`, `spi256*.bin`.
For more information, see [“File Name Convention for Serial Flash Drivers”](#), page 10.

Page A page is the minimum size unit for writing and has a size of 256 bytes.

File Name Convention for Serial Flash Drivers

The serial Flash drivers for SPI controllers, i.e. the algorithm files, use the following file name convention:

Serial Flash driver name: **SPI_{nn}_CPU.bin**

where **nn** is a two-digit number that indicates the size of one sector in KByte (the sector erase size in KByte):

nn	Sector	Hex Size
32	32KB	0x0--0x7FFF
64	64KB	0x0--0xFFFF

where **CPU** is the CPU family name.

Standard Approach

The chapter “Standard Approach” provides a compact description of the steps required to program serial Flash memories. This description is intentionally limited to the standard use case.

Overview of the Standard Approach:

- [Identify and run the required script for serial Flash programming.](#)
- [What to do if there is no script for SPI Flash programming.](#)

The following step-by-step procedures describe the standard approach in detail.

For a detailed description of the serial Flash programming concepts, see “[Scripts for SPI Controllers](#)”, page 14.

Identifying and Running Scripts for Serial Flash Programming

Lauterbach provides scripts (*.cmm) for serial Flash programming which can be found below the TRACE32 installation directory. The scripts support serial Flash memories that have a *serial Flash controller with a SPI interface* (short: SPI controller).

Path and file name convention of scripts to be used with SPI controllers:

~/demo/<architecture>/flash/<cpu_name>-spi.cmm, where ~/ is expanded to the TRACE32 installation directory.

To identify and run the required script:

1. Make a note of the <cpu_name> printed on the CPU; for example, bcm5357
2. Put the <cpu_name> and spi together to form the script name: bcm5357-spi.cmm
The script file resides in this folder: ~/demo/mips/flash/bcm5357-spi.cmm
Note: ~/ is replaced by the TRACE32 installation directory, which is c:/T32 by default.
If the folder does not contain the script you are looking for, see “[If There Is No Script](#)”.
3. Run the script in TRACE32 by doing one of the following:
 - Choose **File** > **Run Script** <cmm_script_name>
 - Or in the TRACE32 command line, type: **DO** <cmm_script_name>

NOTE:

Each PRACTICE script (*.cmm) includes a reference to the required serial Flash programming algorithm (*.bin).
You do not need to program or select the algorithm.

Example

```
;          <code_range>          <data_range>          <algorithm_file>
FLASHFILE.TARGET 0x80020000++0x1FFF 0x80022000++0x3FFF
                ~/demo/mips/flash/byte_le/spi64_bcm5357.bin
```

If There Is No Script

If there is no script for your device in this directory (`~/~/demo/<architecture>/flash/`), please submit a request at support.lauterbach.com/new-ticket using the e-mail template below.

E-Mail Template:

Chip name: _____

Name of serial Flash device: _____

Provide the CPU datasheet for us: _____

Lend the target board to us by sending it to the address given in “[Contacting Support](#)”: _____

<system_information>

Be sure to include detailed system information about your TRACE32 configuration. For information about how to create a system information report, see “[Contacting Support](#)”.

Normally we can provide support for a new device in two weeks.

If our support cannot provide you with a PRACTICE script, you will have to create your own PRACTICE script (*.cmm).

For more information about how to create your own script (*.cmm), see “[Scripts for SPI Controllers](#)”, page 14.

Scripts for SPI Controllers

This chapter describes how to create new scripts for serial Flash memories that are equipped with SPI controllers.

The steps and the framework (see below) provide an overview of the process. They are described in detail in the following sections.

The following steps are necessary to create a new script:

1. **[“Establishing Communication between Debugger and Target CPU”](#)**, page 16
2. **[“Configuring the SPI Controller”](#)**, page 17
3. **[“Resetting Default Values”](#)**, page 18
4. **[“Informing TRACE32 about the Serial Flash Register Addresses \(SPI\)”](#)**, page 18
5. **[“Informing TRACE32 about the Serial Flash Programming Algorithm”](#)**, page 19
6. **[“Checking the Identification from the Serial Flash Device”](#)**, page 26
7. **[“Erasing the Serial Flash Device”](#)**, page 27
8. **[“Programming the Serial Flash Device”](#)**, page 28

The following framework can be used as base for serial Flash programming:

```
                                ; Establish the communication
                                ; between the target CPU and the
                                ; TRACE32 debugger.

                                ; Configure the SPI controller.

FLASHFILE.RESet                ; Reset the serial Flash
                                ; environment in TRACE32 to its
                                ; default values.

FLASHFILE.CONFIG ...          ; Inform TRACE32 about
                                ; - the serial Flash register
                                ;   addresses and
                                ; - the CS address of the serial
                                ;   Flash

FLASHFILE.TARGET ...         ; Specify the serial Flash
                                ; programming algorithm and where
                                ; it runs in target RAM.

FLASHFILE.Erase ...          ; Erase the serial Flash.

FLASHFILE.LOAD <main_file> ... ; Program the file to serial Flash.
```

An ellipsis (...) in the framework indicates that command parameters have been omitted here for space economy.

NOTE: The parametrization of **FLASHFILE.CONFIG** and **FLASHFILE.TARGET** requires expert knowledge.

Establishing Communication between Debugger and Target CPU

Serial Flash programming with TRACE32 requires that the communication between the debugger and the target CPU is established. The following commands are available to set up this communication:

SYStem.CPU <cpu>

Specify your target CPU.

SYStem.Up

Establish the communication between the debugger and the target CPU.

```
SYStem.CPU STM32F103 ; Select STM32F103 as the target CPU.
```

```
SYStem.Up ; Establish the communication between the  
; debugger and the target CPU.
```

Configuring the SPI Controller

Programming a serial Flash device requires an appropriate initialization of the serial Flash interface. The following settings might be necessary:

- Enable the clock (SCLK).
- Configure the registers of the serial Flash interface, such as clock, master/slave, data width, etc.
- Configure the serial Flash pins if they are muxed with other functions of the CPU.

Example: In the CPU STM32F103, all the SPI pins are muxed with the GPIOs.

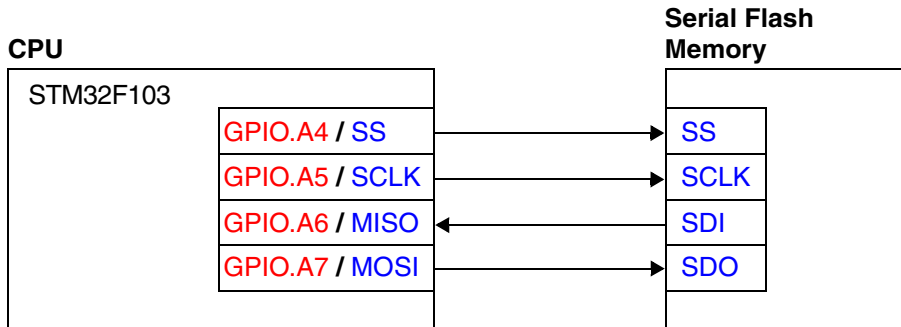

Using the commands below, the pins of the serial Flash interface (SPI) can be configured for the CPU STM32F103. The resulting configuration allows the CPU to switch from the GPIO A4-A7 to SS, SCLK, MISO, and MOSI.

```
PER.Set SD:0x40021014 %Long 0x114 ; Enable the Clock for the
PER.Set SD:0x40021018 %Long 0x100C ; SPI & PIO.

PER.S SD:0x40010800 %Long 0xbbb34444 ; Switch the PIO.A group to
PER.S SD:0x40010810 %Long 0xFFFFFFFF ; the SPI function.

PER.S SD:0x40013000 %WORD 0x34F ; Configure the SPI
PER.S SD:0x40013010 %WORD 0x7 ; controller.
```

Resetting Default Values

The following command is used to reset the serial Flash environment in TRACE32 to its default values.

FLASHFILE.RESet

Reset the serial Flash environment in TRACE32 to its default values.

Informing TRACE32 about the Serial Flash Register Addresses (SPI)

The following command is used to inform TRACE32 about the various register addresses (Flash declaration).

Chip selection is controlled by one GPIO pin.

FLASHFILE.CONFIG <SPI Tx reg> <SPI Rx reg> <CS GPIO reg> <CS bit>

Chip selection is controlled by the SPI controller.

FLASHFILE.CONFIG <SPI Tx reg> <SPI Rx reg> <SPI ChipEnable reg>

Parameters for the FLASHFILE.CONFIG command

<SPI Tx reg>	The transmit data register
<SPI Rx reg>	The receive data register
<CS GPIO reg>	The chip selection GPIO register which is connected to the Flash chip selection
<CS bit>	The chip selection bit in the GPIO CS register
<SPI ChipEnable reg>	The chip enable register of the serial flash

For information about the register addresses and the CS bit, refer to the manufacturer's microcontroller manual and the schematics.

Example 1

```
; For the serial Flash CS connected PIO A.4 (group A, port number 4)
; PIO group A register 0x4001080C
;
;           <SPI Tx reg> <SPI Rx reg> <CS GPIO reg> <CS bit>
FLASHFILE.CONFIG 0x4001300C 0x4001300C 0x4001080C 0x4
```

Example 2

```
; The AT91SAM9XE's CS is controlled by the SPI register 0xFFFC8000, not
; the specified GPIO ports.
;
;           <SPI Tx reg> <SPI Rx reg> <SPI ChipEnable reg>
FLASHFILE.CONFIG 0xFFFC800C 0xFFFC8008 0xFFFC8000
```

Memory-Mapped serial Flash

The FLASH programming is defined using the command **FLASH.TARGET**.

The name of the FLASH algorithm binary file to be used depends on the byte addressing:

- 4 Byte address; **snor_xxxxx.bin** (generally the FLASH size is greater than 16 MBytes).
- 3 Byte address; **snor3b_xxxxx.bin** (the FLASH size is up to 16 MBytes).

Example:

```
FLASH.TARGET 0x900000 0x902000 0x1000 \  
~/demo/arm/flash/byte/snor_imx7.bin
```

Non-Memory-Mapped serial Flash

The FLASH programming algorithm is defined using the command **FLASHFILE.TARGET**. The name of the FLASH algorithm binary file is **spi_xxxxx.bin**.

Required size for the code is `size_of(<file>) + 32` byte.

For detailed information about how to determine the `<file>` parameter, see [“Identifying the Correct Driver Binary File for a Serial Flash Device”](#), page 20.

Identifying the Correct Driver Binary File for a Serial Flash Device

There are two ways to find the correct *.bin file:

- You can identify the *.bin file via our website, as described in this section.
- Alternatively, run a PRACTICE script (*.cmm), as described in “[Finding the <serialflash_code> of Your Serial Flash Device](#)”, page 21.

To identify the correct *.bin file:

1. For information about supported Flash devices, access the [Lauterbach](#) website.
2. Click the + tree button next to **Tool Chain**, and then click **Supported NAND/Serial Flash Controller** (www.lauterbach.com/supported-platforms/toolchain/flash-controllers).
3. Open **Supported Flash Devices** in a separate window or tab (www.lauterbach.com/supported-platforms/toolchain/flash-devices).
4. On the **Supported Flash Devices** page, select the required company from the drop-down list.

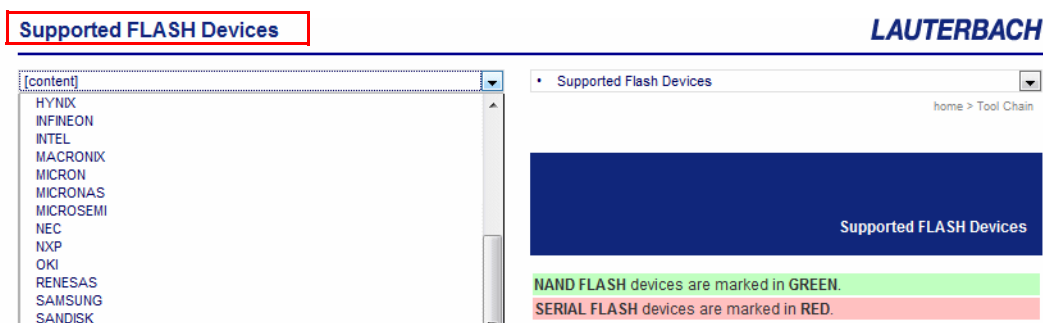

5. Locate the desired Flash device.
You need the name of the Flash device to be able to identify the correct driver binary file.
6. Identify the correct *.bin file based on the name of the Flash device. The following example illustrate how to do this.
 - The example below illustrates how to apply the file name convention in practice.
 - For information about the file name convention for driver binary files, see “[File Name Convention for Serial Flash Drivers](#)”, page 10.

Finding the <serialflash_code> of Your Serial Flash Device

The following step-by-step procedure helps you find the <serialflash_code> of your serial Flash device. Based on the <serialflash_code>, you can then identify the correct *.bin file.

To find the <serialflash_code>:

1. Run the following PRACTICE script file (*.cmm) from the TRACE32 demo folder:

```
CD.DO ~/demo/etc/flash/find_spidef.cmm

;The path prefix ~~ expands to the system directory of TRACE32,
;by default C:\t32.
```

If this demo script is missing, you can download it from www.lauterbach.com/support-and-training/downloads.

The **Find SPI flash code** dialog opens.

2. Under **spi flash parameters**, make your settings.
 - You can find the required information in the serial Flash documentation of the manufacturer.
 - For an example of where to search for the information, see figure and table below:

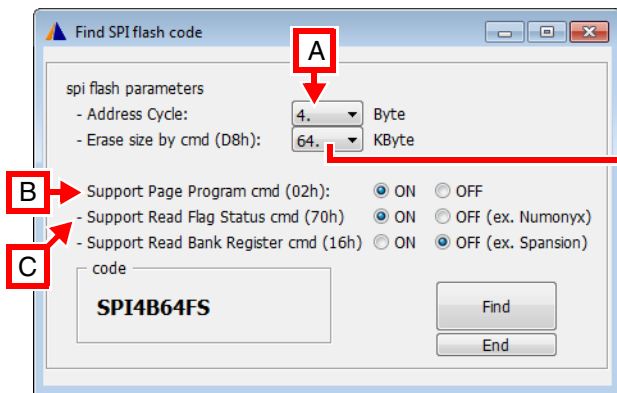

In the serial Flash documentation of the manufacturer, search for terms like:

- erase capability
- sector
- granularity

in order to find the correct value.

	Instruction	Description	One-Byte Instruction Code (BIN)	One-Byte Instruction Code (HEX)	Address Bytes	Dummy Clock Cycle	Data Bytes
	...						
A	READ	Read Data Bytes	0000 0011	03h	3/4	0	1 to ∞
	...						
B	PP	Page Program	0000 0010	02h	3/4	0	1 to 256
	...						
C	RFSR	Read Flag Status Register	0111 0000	70h	0	0	1 to ∞

- Click **Find**.
 - The **code** box displays the *<serialflash_code>* of your serial Flash device.
 - If the **code** box displays **unknown**, then proceed as described in “**If There is No Script**”.
- Make a note of the displayed *<serialflash_code>*.
- Click **End** to close the dialog.
- Identify the correct *.bin file based on the *<serialflash_code>*. The following example illustrates how to do this.
 - “**Example for SPI Controllers**”, page 23
 - For information about the file name convention for driver binary files, see “**File Name Convention for Serial Flash Drivers**”, page 10.

Example for SPI Controllers

Target:

- ARM-based **STM32F10X** CPU with the SPI controller **stm**
- Serial Flash device **M25P64**

Taken together, the **Code** column and the **Controller** column make up the file name of the serial Flash driver binary file: **spi64_stm.bin**. The number **64** indicates the size of one sector in KByte (the sector erase size in KByte).

ST Microelectronics N.V.

CPU	CONTROLLER	COMMENT
SPEAR300	generic	NAND
⋮	⋮	⋮
STM32F103ZE	cortexm3	NAND
STM32F10X	stm	SPI
STM32F105		

ST Microelectronics N.V.

TYPE	COMPANY	CODE	COMMENT
M25FL128	STM	SPI256	Serial Flash, 256KB sector
M25P64	STM	SPI64	Serial Flash
M28F101	STM	M28F256	
M28F102	STM	M28F256	
M28F201	STM	M28F256	

The binary file resides in this folder: `~/~/demo/arm/flash/byte`

Note: `~/~` is expanded to the TRACE32 installation directory, which is `c:/t32` by default.

This results in the following command line:

```
; Specify the serial Flash programming algorithm and where it runs in  
; the target RAM. <code_range> <data_range> <file>  
FLASHFILE.TARGET 0x20000000++0x1FFF 0x20002000++0x1FFF  
~/~/demo/arm/flash/byte/spi64_stm.bin
```

FLASHFILE Declaration Examples

Declaration Example for STM32F103 (Cortex-M3)

STM32F103 (ARM Cortex-M3) from ST Microelectronics, M25P64 (64Mbit)

- SPI Tx register/SPI Rx register: 0x4001300C
- Sector size: 64Kbytes (0x0--0xFFFF)
- Driver file: ~/demo/arm/flash/byte/spi64_stm.bin

Note: ~/ is expanded to the TRACE32 installation directory, which is c:/T32 by default.

```
...  
  
; Reset the FLASHFILE declaration within TRACE32.  
FLASHFILE.RESet  
  
; For the serial Flash CS connected PIO A.4 (Group A, port Number4)  
; PIO group A register 0x4001080C  
; <SPI Tx reg> <SPI Rx reg> <CS GPIO reg> <CS bit>  
FLASHFILE.CONFIG 0x4001300C 0x4001300C 0x4001080C 0x4  
  
; Specify the serial Flash programming algorithm and where it runs on  
; the target RAM.  
FLASHFILE.TARGET 0x20000000++0x1FFF 0x20002000++0x1FFF  
~/demo/arm/flash/byte/spi64_stm.bin  
  
...
```

Declaration Example for AT91SAM9XE (ARM9)

AT91SAM9XE (ARM9) from ATMEL, M25P64 (64Mbit)

- SPI Tx register/SPI Rx register: 0xFFFFC800C / 0xFFFFC8008
- Sector size: 64Kbytes (0x0--0xFFFF)
- Driver file: ~/demo/arm/flash/byte/spi64_at91sam.bin

Note: ~ is expanded to the TRACE32 installation directory, which is c:/t32 by default.

```
...  
  
; Reset the FLASHFILE declaration within TRACE32.  
FLASHFILE.RESet  
  
; The AT91SAM9XE's CS is controlled by the SPI register 0xFFFFC8000 not  
; the specified GPIO ports.  
;           <SPI Tx reg> <SPI Rx reg> <SPI ChipEnable reg>  
FLASHFILE.CONFIG 0xFFFFC800C      0xFFFFC8008      0xFFFFC8000  
  
; Specify the serial Flash programming algorithm and where it runs on  
; the target RAM.  
FLASHFILE.TARGET 0x300000++0x1FFF 0x302000++0x1FFF  
                    ~/demo/arm/flash/byte/spi64_at91sam.bin  
  
...
```

Checking the Identification from the Serial Flash Device

The following command can be used to check if TRACE32 can access the serial Flash device:

FLASHFILE.GETID

Get the ID values of the serial Flash device.

```
; Open the TRACE32 AREA window.
```

```
AREA.view
```

```
; Check the access to the serial Flash device
```

```
; by getting the manufacturer ID and the device ID.
```

```
FLASHFILE.GETID
```

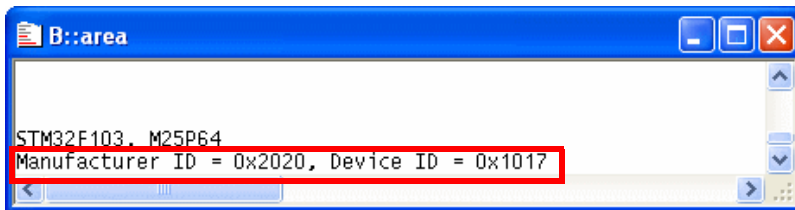

Erasing the Serial Flash Device

The following command is available to erase serial Flash devices:

FLASHFILE.Erase <range>

Erase the serial Flash.

NOTE:

The **FLASHFILE.Erase** command has a time limitation.

- TRACE32 has to get a response (success or failure) from the serial Flash in 3 minutes.
- If you get an error message because of the **FLASHFILE.Erase** time limitation, then divide the original range into several smaller ranges.

Example 1: Original erase range

```
; Erase 2MB starting from 0x0.  
FLASHFILE.Erase 0x0--0x1FFFFFF
```

Example 1 cont'd: Two smaller erase ranges

```
; Erase 2MB starting from 0x0.  
FLASHFILE.Erase 0x0--0xFFFFF  
FLASHFILE.Erase 0x100000--0x1FFFFFF
```

Example 2: Erase 8 MB in increments of 1 MB using a **RePeaT** loop

```
&addr=0x0  
RePeaT 8.  
(  
  FLASHFILE.Erase &addr++0xFFFFF  
  &addr=&addr+0x100000  
)
```

Programming the Serial Flash Device

The following commands are available to program the serial Flash:

```
FLASHFILE.LOAD <file> [<address> | <range>]           Program serial Flash.  
FLASHFILE.LOAD <file> [<address> | <range>] /ComPare
```

The data from <file> is written to the address range specified by <range>. If no <range> or <address> is specified, programming starts at address 0x0.

Example 1

```
; Program the contents of my_file.bin to the serial Flash memory starting  
; at address 0x0.  
FLASHFILE.LOAD my_file.bin 0x0
```

Example 2

```
; Verify the contents of my_file.bin against the serial Flash memory  
; starting at address 0x0.  
FLASHFILE.LOAD my_file.bin 0x0 /ComPare
```

Copying the Serial Flash Memory

The following command is available to copy:

- Any data from any CPU memory area to the serial Flash memory, or
- Any data from one address range of the serial Flash to another address range within the same serial Flash memory; for example, for backup purposes.

FLASHFILE.COPY <source range> <target addr>

Copy data from the source range to the defined address of the serial Flash.

FLASHFILE.COPY <source range> <target addr> /ComPare

Verify the source range data against the target range data.

Example 1

```
; Copy the 1MB virtual memory data at 0x0 to the serial Flash address  
; at 0x100000.  
; VM: The virtual memory of the TRACE32 software.  
FLASHFILE.COPY VM:0x0--0xFFFFF 0x100000
```

Result (1)

The image shows two overlapping windows from a debugger. The top window, titled 'B::DATA.DUMP VM:0x0 /DIALOG', displays a memory dump for VM:0x0. The bottom window, titled 'B::FLASHFILE.DUMP 0x100000', displays a memory dump for the serial flash starting at address 0x100000. A red arrow points from the VM:0x0 data to the flash data, indicating that the data from the CPU memory is being copied to the serial flash.

Data is copied from the CPU to the serial Flash

Example 2

```
; Verify the data between virtual memory and serial Flash.  
FLASHFILE.COPY VM:0x0--0xFFFFF 0x100000 /ComPare
```

Example 3

```
; Copy the 1MB serial Flash data at 0x0 to the serial Flash  
; at 0x800000.
```

```
FLASHFILE.COPY 0x0--0xFFFFF 0x800000
```

```
; Verify the 1MB serial Flash data between 0x0 and 0x800000.
```

```
FLASHFILE.COPY 0x0--0xFFFFF 0x800000 /ComPare
```

Other Useful Commands

The CPU cannot read serial Flash memories directly. But TRACE32 provides special commands for reading serial Flash memories. The contents of the serial Flash are displayed in a window.

Reading the Serial Flash

The following command allows to read the serial Flash memory.

FLASHFILE.DUMP [*<address>*] [*/<format>*] Display a hex-dump of the serial Flash.

Example

```
; Display a hex-dump of the serial Flash starting at 0x1000.  
; Display the information in a 32-bit format (/Long option).  
FLASHFILE.DUMP 0x1000 /Long
```

Result

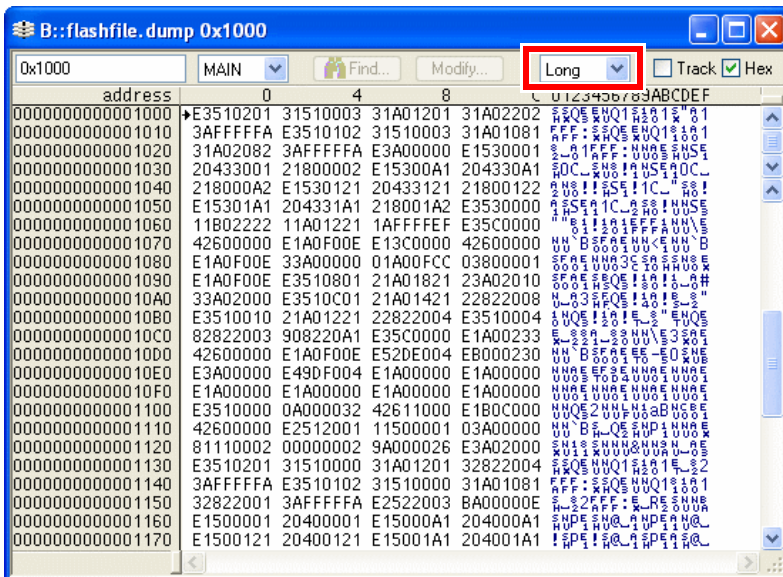

Saving the Serial Flash Device

The following command is available to save the contents of the serial Flash memory to a file.

FLASHFILE.SAVE *<file>* *<range>*

Save the contents of the serial Flash memory into *<file>*.

Example

```
; Save 1MB of the serial Flash data starting at 0x0 to the file  
; my_dump.bin.  
FLASHFILE.SAVE my_dump.bin 0x0--0xFFFFF
```

Example 1

CPU: STM32F103 (Cortex-M3 core)
Serial Flash: M25P64 (STMicroelectronics, 64Mbit)
Serial Flash CS: Connected to GPIO B.2

```
RESet
SYStem.RESet
SYStem.CPU STM32F103ZE
SYStem.Up

gosub enable_SPI

; Reset the Flash declaration within TRACE32.
FLASHFILE.RESet

; For the serial Flash CS connected GPIO B.2 (group B, port number2)
; GPIO B.2 data output register 0x40010C0C
;
;           <SPI Tx reg> <SPI Rx reg> <CS GPIO reg> <CS bit>
FLASHFILE.CONFIG 0x4001300C  0x4001300C  0x40010C0C  0x2

FLASHFILE.TARGET 0x20000000++0x1fff 0x20002000++0x1FFF
                ~/demo/arm/flash/byte/spi64_stm.bin

; Read Flash manufacture and device ID.
FLASHFILE.GETID

; Erase serial Flash.
FLASHFILE.Erase 0x0--0xFFFFF

; Program my_file.bin to serial Flash.
FLASHFILE.LOAD my_file.bin 0x0
```

```

; Save to my_dump.bin from serial Flash
FLASHFILE.SAVE my_dump.bin 0x0--0xFFFFF

enable_SPI:

; Clock Enable related with the SPI and GPIO group
PER.S SD:0x40021014 %Long 0x114 ; FSCM Clock Enable
PER.S SD:0x40021018 %Long 0x100C ; SPI1 & GPIO A/B Enable

PER.S SD:0x40010C00 %LONG 44444344 ; GPIOB.2 output
PER.S SD:0x40010C0C %LONG 00000004 ; deselect the SPI FLASH CS(GPIOB.2)

PER.S SD:0x40013000 %WORD 0x30F ; SPI_Init
PER.S SD:0x40013010 %WORD 0x7 ; SPI_CRC pol

&spi_enable=Data.word(SD:0x40013000)|0x40
PER.S SD:0x40013000 %WORD &spi_enable ; SPI1 Enable

return

ENDDO

```

Example 2

CPU: The STR91x is based on a ARM966E core. It has a SSP protocol which is similar to a STM SPI controller.

Serial Flash: ST Microelectronics M25P64 (64Mbit)
Serial Flash is connected to GPIO 5.7 on the STR91x.
Then it is controlled by GPIO5 register (0x5800B3FC).

```
; Select str910 as target CPU.
; Establish the communication between the debugger and the target CPU.
SYStem.RESet
SYStem.CPU STR910
SYStem.Option.ResBreak OFF
SYStem.JtagClock RTCK
SYStem.Up

; Enable SSP (Synchronous Serial Peripheral) & configuration of pins.
PER.Set ASD:0x5C002018 %Long 0x80300
PER.Set ASD:0x5C002020 %Long 0x80300
PER.Set ASD:0x5C002028 %Long 0x80300
PER.Set ASD:0x5800B400 %Long 0xb0
PER.Set ASD:0x5C002058 %Long 0x4a00
PER.Set ASD:0x5C002098 %Long 0x0
PER.Set ASD:0x5C002078 %Long 0x40
PER.Set ASD:0x5C007000 %Long 0x5c7 ;SSP0_CR0
PER.Set ASD:0x5C007010 %Long 0x2 ;SSP0_PR
PER.Set ASD:0x5C007004 %Long 0x2 ;SSP0 Enable

FLASHFILE.RESet

;          <SPI Tx Reg> <SPI Rx Reg> <CS GPIO reg> <CS bit>
FLASHFILE.CONFIG 0x5C007008 0x5C007008 0x5800B3FC 0x7

;          <code_range>          <data_range>          <algorithm_file>
FLASHFILE.TARGET 0x4000000++0x1FFF 0x4002000++0x1FFF
                ~/demo/arm/flash/byte/spi64_stm.bin

; Programming for the serial Flash
FLASHFILE.GETID
FLASHFILE.ERASE 0x0--0xFFFFF
FLASHFILE.LOAD * 0x0
FLASHFILE.SAVE dump.bin 0x0--0xFFFFF
ENDDO
```

FLASH Programming via Boundary Scan

The **BSDL** commands of TRACE32 are used to program external FLASH memories via boundary scan. Important BSDL-specific steps are:

- Check that the bypass mode works.
- Check that the IDCODE matches.
- Define the FLASH pin connection.
- Enable serial FLASH programming via boundary scan and define the flash type.

Serial FLASH programming then continues with the **FLASHFILE** commands described in this manual. The following PRACTICE script (*.cmm) illustrates the BSDL-specific steps by way of these examples:

- [Example 1](#) for the SPI protocol
- [Example 2](#) for the I2C protocol

Example 1 for the SPI Protocol

CPU:	AT91SAM3U4
Serial FLASH:	M25P64 (STMicroelectronics, 64Mbit)
Pin connection:	SPI_CE: Port A16 SPI_SCK: Port A15 SPI_MOSI: Port A14 SPI_MISO: Port A13

```

SYStem.JtagClock 15.Mhz           ; set JTAG clock
BSDL.RESet                       ; reset boundary scan configuration
BSDL.FILE ./sam3u4e_lqfp144.bsdl ; load the required BSDL file

BSDL.HARDRESET                   ; toggle TRST_N pin
BSDL.SOFTRESET                   ; do a sequential JTAG reset

IF BSDL.CHECK.BYPASS()           ; check, if BYPASS mode works
(
  IF BSDL.CHECK.IDCODE()         ; check, if the IDCODE matches
  (
    BSDL.FLASH.IFDefine RESet    ; reset the boundary scan flash
                                ; configuration
    BSDL.FLASH.IFDefine SPI 1.   ; define boundary scan flash interface:
                                ; - protocol: SPI
                                ; - SPI flash memory connected to IC1
                                ;   of the boundary scan chain

    BSDL.FLASH.IFMap CE PA16     ; map generic SPI pin CE to port PA16
    BSDL.FLASH.IFMap SCK PA15    ; map generic SPI pin SCK to port PA15
    BSDL.FLASH.IFMap SI PA14     ; map generic SPI pin SI to port PA14
    BSDL.FLASH.IFMap SO PA13     ; map generic SPI pin SO to port PA13
    BSDL.FLASH.INIT SAFE         ; Initialize boundary scan chain to
                                ; safe values according to SAFE state
                                ; from BSDL file

    FLASHFILE.BSDLaccess ON      ; Enable serial flash programming via
                                ; boundary scan
    FLASHFILE.BSDLFLASHTYPE SPI64 ; define serial flash type

    FLASHFILE.GETID              ; get the SPI flash memory ID
    ; continue with serial flash programming, e.g.:
    ; FLASHFILE.DUMP 0x0
    ; FLASHFILE.ERASE 0x0--0xFFFFF
    ; FLASHFILE.LOAD * 0x0
  )
)
ENDDO

```

Example 2 for the I2C Protocol

CPU: AT91SAM3U4
eMMC FLASH: ST24C08 (STMicroelectronics, 8kbit)
Pin connection: I2C_SCL: Port A25
I2C_SDA: Port A24

```
SYStem.JtagClock 15.Mhz           ; set JTAG clock

BSDL.RESet                       ; reset boundary scan configuration

BSDL.FILE ./sam3u4e_lqfp144.bsdl ; load the required BSDL file

BSDL.HARDRESET                   ; toggle TRST_N pin
BSDL.SOFTRESET                   ; do a sequential JTAG reset

IF BSDL.CHECK.BYPASS()           ; check, if BYPASS mode works
(
  IF BSDL.CHECK.IDCODE()         ; check, if the IDCODE matches
  (
    BSDL.FLASH.IFDefine RESet    ; reset the boundary scan flash
                                ; configuration

    BSDL.FLASH.IFDefine I2C 1.   ; define boundary scan flash interface:
                                ; - protocol: I2C
                                ; - I2C flash memory connected to IC1 of
                                ;   the boundary scan chain

    BSDL.FLASH.IFMap SCL PA25    ; map generic I2C pin SCL to port PA25
    BSDL.FLASH.IFMap SDA PA24    ; map generic I2C pin SDA to port PA24
    BSDL.FLASH.INIT SAFE        ; Initialize boundary scan chain to safe
                                ; values according to SAFE state
                                ; from BSDL file

    FLASHFILE.BSDLaccess ON     ; Enable serial flash programming via
                                ; boundary scan
    FLASHFILE.BSDLFLASHTYPE I2C08 ; define serial flash type

    FLASHFILE.GETID             ; get the I2c flash memory ID
                                ; continue with serial flash programming, e.g.:
                                ; FLASHFILE.DUMP 0x0
                                ; FLASHFILE.ERASE 0x0--0x3FF
                                ; FLASHFILE.LOAD * 0x0
  )
)
ENDDO
```